

### PARTS LIST

Quantities shown below include all spools on this drawing

Item	Qty	Part Description	Mtl.	DetRef
1	1	WSP: 25.75"OD x 1/4" w x 13'-2-1/4"Lg	C-200	005
2	1	Harness back Ring: 34.75"OD x 25.88"ID x 1/2"thk; w/4 ea -1.13"dia holes on a 32.25"BC	A-36	920D
3	1	Harness Front Ring: 29.75"OD x 25.88"ID x 1/2"thk	A-36	920D
4	8	Harness Gussets: 4-5/8"long x 4-1/2"tall, shaped	A-36	920D

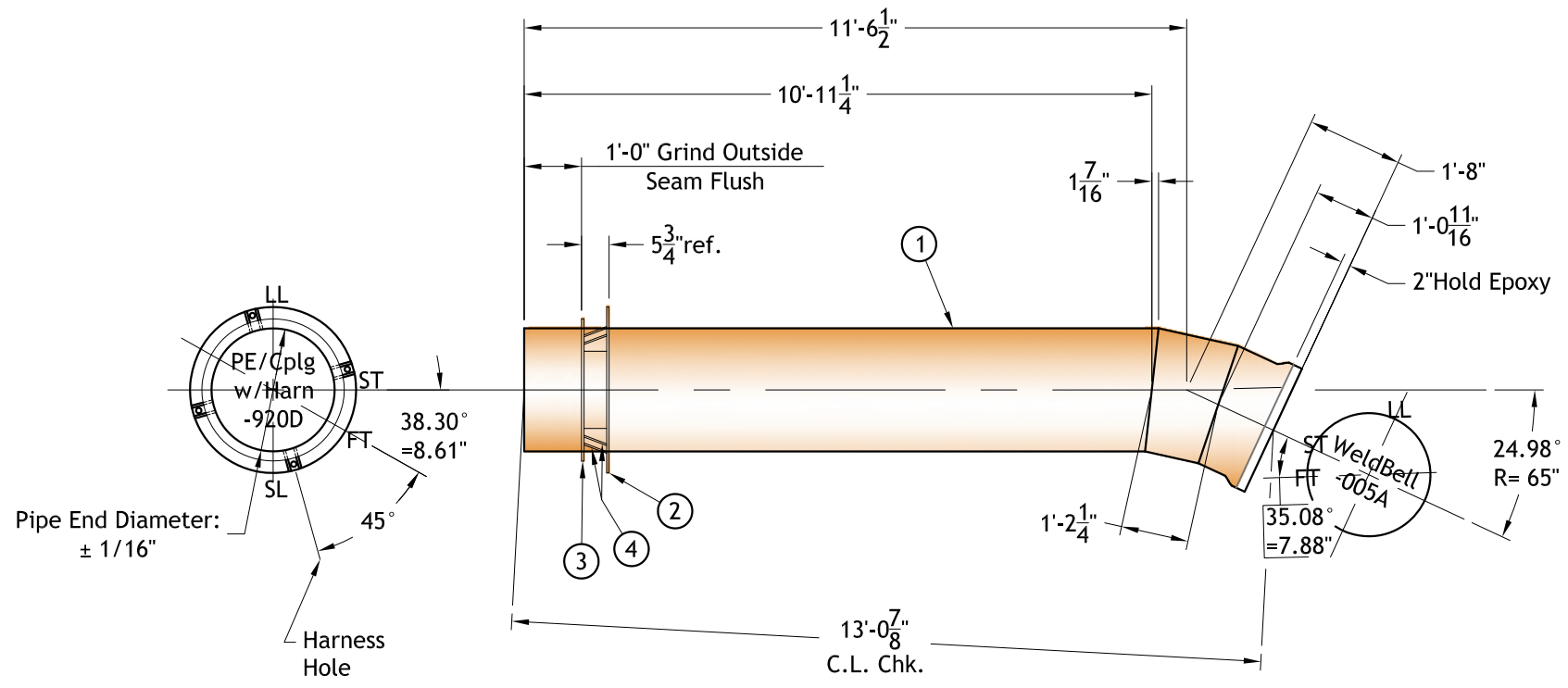

EXTERIOR COATING	15-17mils	Amine-Cured Epoxy	Devoe 233HB	C-210; SP-10
INTERIOR LINING	1/2"	Cement Mortar	C-150 Type II/V	C-205
	Thickness	Material	Material Spec.	Application Spec.

JOINT NUMBER(S)	QTY.	WEIGHT
3	1 each	1,500 lbs/ea <small>108lbs/ft</small>

*JOINTS ON THIS DRAWING*

*PIPE FINISHING DATA*

IPS Customer:

**Customer Name**

Project Description:

**Agency Name  
Project Name**

Note: Dimensions are in U.S. Customary Units: Decimal Feet & Inches, Decimal Degrees, and Pounds, Unless Noted Otherwise.

Sales Rep: **Dennis Rea**

Designed by: **N.R. Boucher**



12375 Brown Avenue,  
Riverside, CA 92509  
951.682.3307; Fax: 682.3406  
www.imperialpipe.com

Drawing Title: **24" Harness x WB, 2-Cut Elbow**

Drawing Date: **10-Apr-08**

Drawing Number (fn): **WebSamp-203**

Rev. **00**

REVIEWING ENGINEER OR CUSTOMER TO COMPLETE

APPROVED AS DRAWN

APPROVED W/NOTED CORRECTIONS

REVISE & RESUBMIT

SIGNED: \_\_\_\_\_ DATE: \_\_\_\_\_

PRINT YOUR NAME: \_\_\_\_\_

Rev	By	Date	Description of Change(s)
~	~	~	~